

ZABBIX



with a pinch of Salt

'Salt Crystals' by
Mark Schellhase





@RaymondKuiper



nl.linkedin.com/in/raymondkuiper



github.com/q1x

Configuration Management



(Or: How I learned to stop worrying and love automation)

'Salt Crystals' by
Mark Schellhase



'SALTSTACK



puppet



ANSIBLE

'Badwater Salt Flats at Twilight'
by Photographersnature





RETAILSTEKKER

Uw retailverbinding

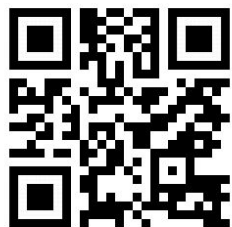

WINKELS

HOME / WINKELS

248

OP VASTE LIJN



15

OP 4G



2

OFFLINE



0

GEPLAND



5

ONBEKEND



TICKETS

TICKET NR

OMSCHRIJVING

STATUS

Kies een locatie

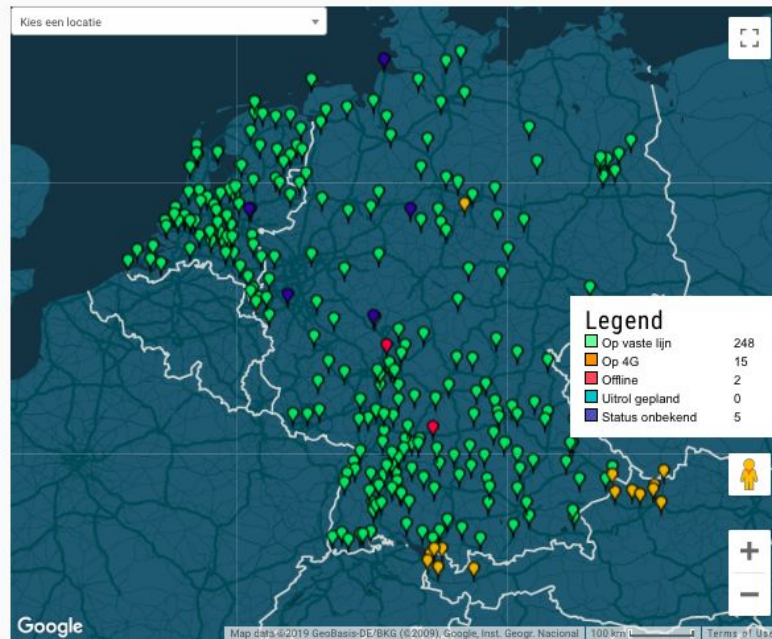

Google

Map data ©2019 GeoBasis-DE/BKG (©2009), Google, Inst. Geogr. Nacional | 100 km

[volledig scherm]

DASHBOARDS ×

WINKELS

LOCATIES

LIJNAANVRAGEN

VOORKEUREN

ADMIN

ALERTING

LOGOUT

HISTOGRAM

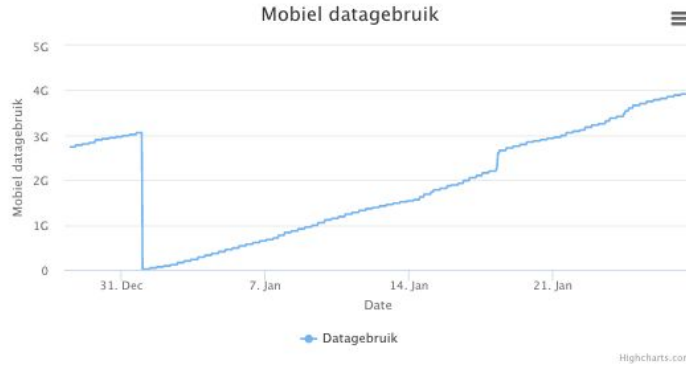
LATENCY(24H) LATENCY(30D) PACKETLOSS(24H) PACKETLOSS(30D) AVAILABILITY(24H)
AVAILABILITY(30D) MOBILE DATA(24H) **MOBILE DATA(20D)**

INFO

ALGEMEEN DSL MOBIEL

Verbinding status: onbackup
Actieve verbinding: Cellular
Lokaal subnet: 10.3.6.0/24

TOOLS

START DIAGNOSE VASTE VERBINDING

LED STATUS ROUTER OPVragen

ROUTER HERSTARTEN

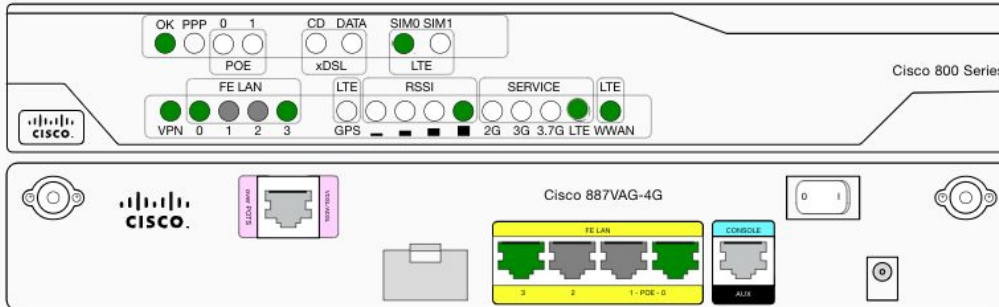

ZABBIX at Netco

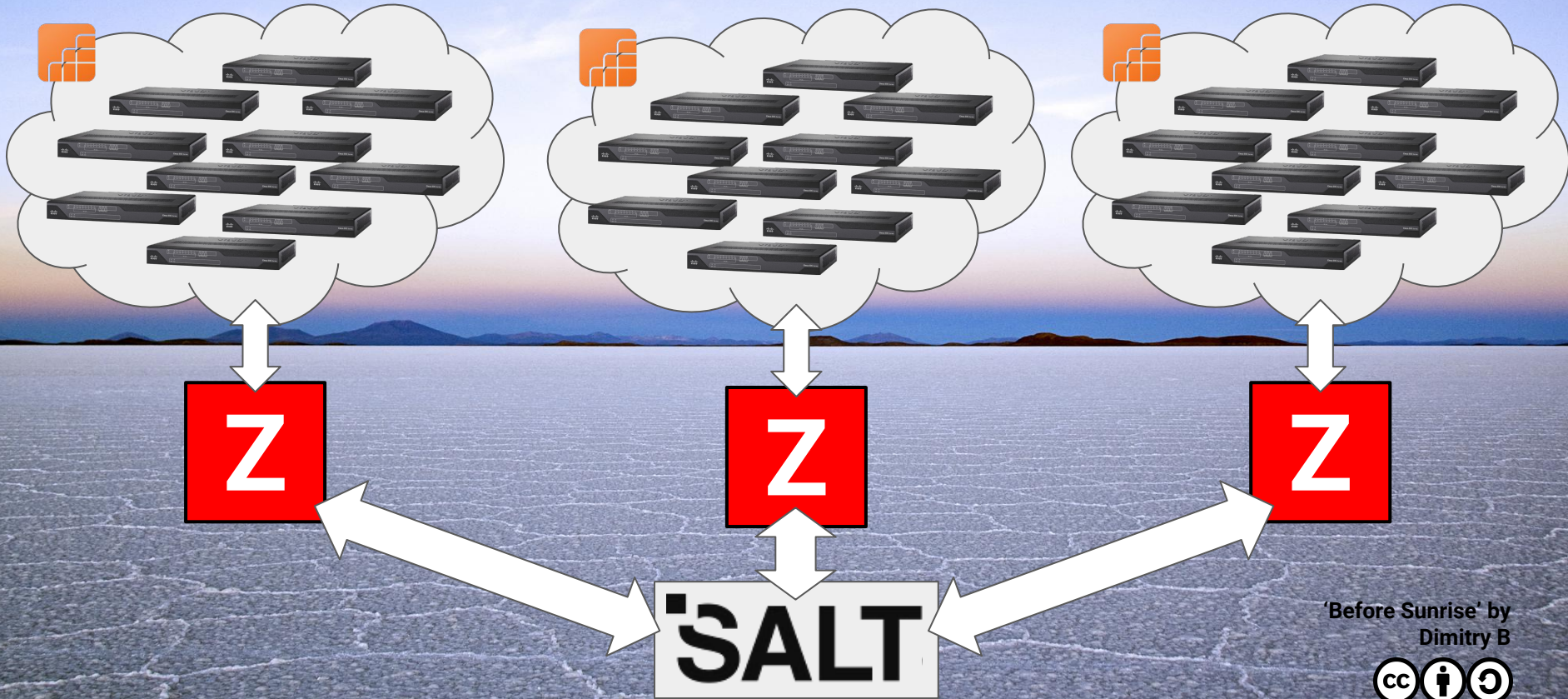

'Before Sunrise' by
Dimitry B





Grafana



'Badwater Salt Flats at Twilight'
by Photographersnature



SaltStack



A quick introduction

'Salt Crystals' by
Mark Schellhase



SaltStack is:

- ❑ An event-driven automation platform based on pub/sub
 - ❑ Configuration Management System
 - ❑ Remote Execution System
 - ❑ ...
- ❑ Build with Python



SaltStack eventbus

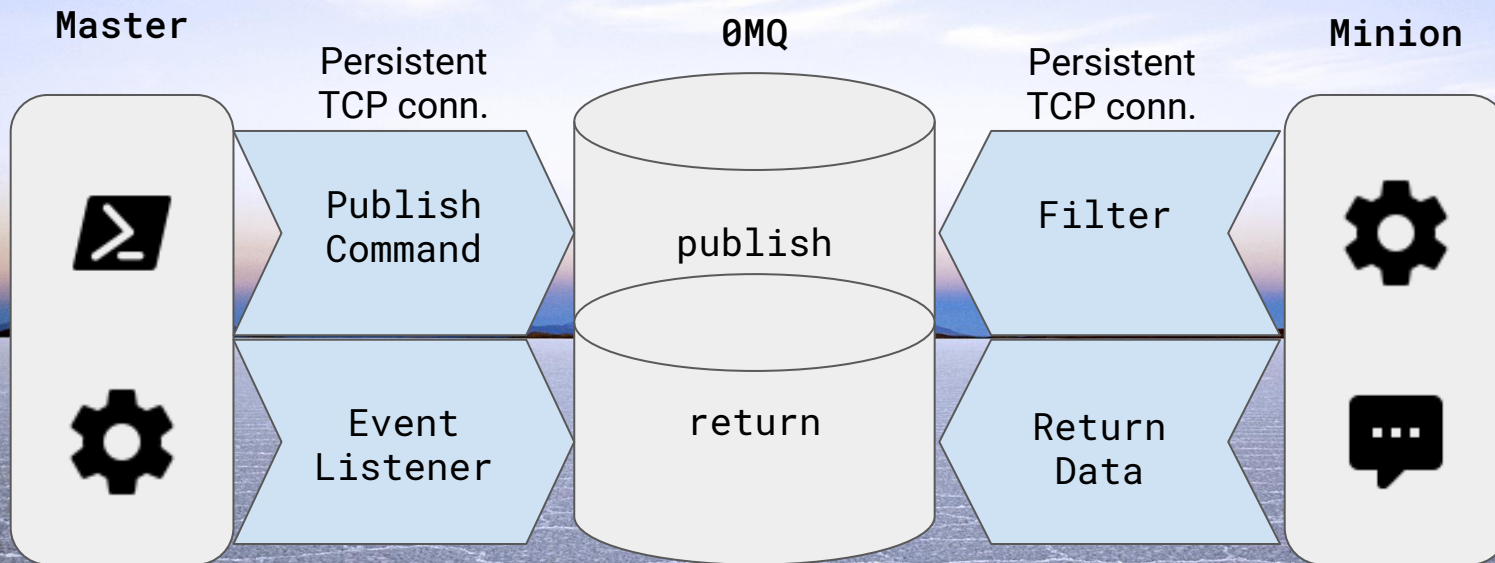

'Before Sunrise' by
Dimitry B



Grains and Pillar

Grains:

- ❑ Key/Value store
- ❑ Minion Attributes
- ❑ Think: Facts



Pillar:

- ❑ Key/Value store
- ❑ Master (secret) data
- ❑ Think: Hiera



'Salt Pillar at the Dead Sea, Isreal'
by Yair Aronshtam



Mine

- ❑ Key/Value store
- ❑ Inter-minion data
- ❑ Think: Exported resources



'Turda Salt mine - tunel de acces'
by Cristian Bortes



Targeting

- ❑ Minion id (Globbing / Regexp)
- ❑ Grains / Pillar
- ❑ Compound matching

```
salt -C 'webserv* and G@os:Debian' test.ping
```

Glob

Grain



'Bonneville Salt Flats'
by Michael Pätzold



Modules and Functions

Modules:

- ❑ Python files
- ❑ Execution, state, etc...

Functions:

- ❑ Python functions (within module)
- ❑ Uses args & kwargs

```
salt 'zabbix*' cmd.run 'ls /tmp' runas='zabbix'
```



States

YAML files describing desired state

```
$ cat /srv/salt/vim.sls
vim:
  pkg.installed

/etc/vimrc:
  file.managed:
    - source: salt://files/vimrc
    - mode: 644
    - user: root
    - group: root
```

```
$ salt '*' state.apply vim
```



'Badwater Salt Flats at Twilight'
by Photographersnature



States

Built-in Jinja2 support

```
$ cat /srv/salt/motd.sls
motd:
  file.managed:
    {% if grains['os'] == 'Debian' %}
    - name: /etc/motd.tail
    {% else %}
    - name: /etc/motd
    {% endif %}
    - source: salt://motd
```



'Badwater Salt Flats at Twilight'
by Photographersnature



Formulas

- ❑ Collections of pre-written states
- ❑ Allow for platform independent application management
- ❑ Think: Puppet modules



There's a lot more!

- ❑ Orchestration
- ❑ Salt Cloud
- ❑ Salt Beacons
- ❑ Salt Reactor
- ❑ Network Automation
- ❑ ...



'Turda Salt mine - tunel de acces'
by Cristian Bortes



ZABBIX



in the SaltStack ecosystem

'Salt Crystals' by
Mark Schellhase



Formula

Installs Zabbix components

```
$ cat /srv/salt/top.sls
```

```
base:
```

```
  '*':
```

- zabbix.agent.repo
- zabbix.agent.conf

```
$ cat /srv/pillar/zabbix-agent.sls
```

```
zabbix:
```

```
  lookup:
```

```
    agent:
```

```
      version: '4.0'
```



'Badwater Salt Flats at Twilight'
by Photographersnature



Execution module

Exposes the Zabbix API to SaltStack

```
$ cat /srv/pillar/zabbix-server.sls
...
zabbix.user: Admin
zabbix.password: zabbix
zabbix.url: http://127.0.0.1/zabbix/api_jsonrpc.php

$ salt 'zabbix' zabbix.hostgroup_create MyNewGroup
```



'Before Sunrise' by
Dimitry B



State modules

Desired state through the Zabbix API

- ❑ `zabbix_host`
- ❑ `zabbix_hostgroup`
- ❑ `zabbix_mediatype`
- ❑ `zabbix_user`
- ❑ `zabbix_usergroup`



Examples



'Salt Crystals' by
Mark Schellhase



External scripts

```
$ cat /srv/salt/zabbix-server/scripts.sls
...
external-scripts:
  git.latest:
    - name: https://gitlab.local/zabbix/external-scripts.git
    - target: /opt/zabbix/scripts/external
    - force_reset: True
    - require:
      - pkg: git
...
```

'Badwater Salt Flats at Twilight'
by Photographersnature



Template Sync

```
$ cat /srv/salt/zabbix-server/templates.sls
...
templates:
  file.directory:
    - name: /opt/zabbix/templates/
  git.latest:
    - name: https://gitlab.local/zabbix/templates.git
    - target: /opt/zabbix/templates/
    - require:
      - pkg: git
  cmd.run:
    - name: /opt/zabbix/scripts/template-import.py -v -T /opt/zabbix/templates/
    - runas: zabbix
    - onchanges:
      - git: templates
```

'Before Sunrise' by
Dimitry B



LDAP auth

```
$ cat /srv/salt/zabbix-server/ldap.sls
{%- if salt['pillar.get']('zabbix.ldap', {}) %}
{%- set ldap = salt['pillar.get']('zabbix.ldap') %}
enable Zabbix ldap auth:
  mysql_query.run:
    - database: zabbix
    - query: "UPDATE config SET authentication_type=1,
             ldap_host='ldap://{{ ldap.host }}', ldap_port={{ ldap.port }},
             ldap_base_dn='{{ ldap.basedn }}', ldap_bind_dn='{{ ldap.binddn }}',
             ldap_bind_password='{{ ldap.password }}',
             ldap_search_attribute='{{ ldap.search }}'"
{%- endif %}
```



Can we get some love for ZBXNEXT-4268?

Media

```
$ cat /srv/salt/zabbix-server/mediatypes.sls
...
Zabbix email mediatype:
  zabbix_mediatype.present:
    - name: 'Email'
    - mediatype: 0
    - smtp_server: localhost
    - smtp_helo: {{ salt['grains.get']('id','localhost') }}
    - smtp_email: 'zabbix@example.com'
...
```

'Badwater Salt Flats at Twilight'
by Photographersnature



User groups

```
$ cat /srv/pillar/zabbix-server.sls:
zabbix.usergroups:
  - Admins
  - Users

$ cat /srv/salt/zabbix-server/usergroups.sls
{%- for usergroup in salt['pillar.get']('zabbix.usergroups',[]) %}
  {{ usergroup }}:
    zabbix_usergroup.present:
      - rights:
          # Add RO rights to any hostgroup
          {%- for group in salt['zabbix.hostgroup_list']() %}
            - { id: {{ group['groupid'] }}, permission: "2" }
          {%- endfor %}
      - gui_access: 0
  {%- endfor %}
```

'Before Sunrise' by
Dimitry B



LDAP users

```
$ cat /srv/salt/zabbix-server/users.sls
{%- for username in salt['cmd.run']("getent group \
                                     'grp-zabbix-users'").split(':')[3].split(',') %}
Zabbix user {{ username }}:
  zabbix_user.present:
    - alias: '{{ username }}'
    - passwd: ''
    - password_reset: False
    - usrgrps:
      - Admins
    - medias:
      - mediatypeid: {{ salt['zabbix.mediatype_get'](name='Email') }}
      - sendto: '{{ username }}@example.com'
      - active: 0
      - severity: 63
      - period: '1-7,00:00-24:00'
{%- endfor %}
```

Create Host

```
$ cat /srv/salt/zabbix-server/hosts.sls
```

```
Zabbix server:
```

```
zabbix_host.present:
```

- host: Zabbix server
- interfaces:
 - localhost:
 - ip: '127.0.0.1'
 - type: 'agent'
- groups:
 - 'Zabbix Servers'

```
zabbix_host.assign_templates:
```

- host: Zabbix server
- templates:
 - 'Template Zabbix Server'

```
...
```

'Badwater Salt Flats at Twilight'
by Photographersnature



Further down the rabbit hole

- ❑ Marco support (works!)
- ❑ Actions via states
- ❑ Grafana config via Mine
- ❑ Monitor Salt with Zabbix
- ❑ Forward Zabbix events to Salt
- ❑ ...

'Turda Salt mine - tunel de acces'
by Cristian Bortes



Q&A



'Salt Crystals' by
Mark Schellhase

